

ACTIVANKLE® Cleaning Instructions

Read Entire Instructions Before Proceeding

Rampro

Parts List

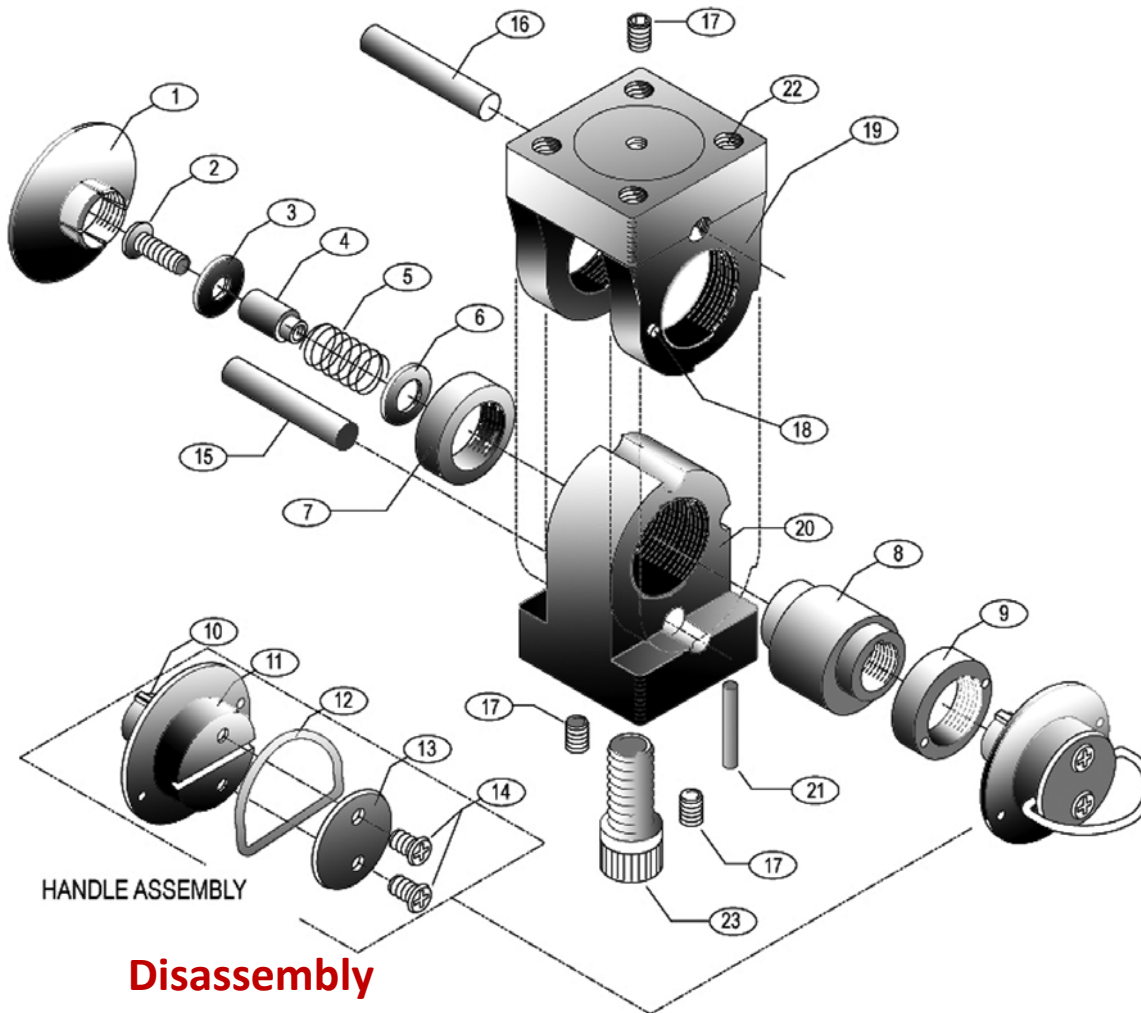

1. End Cap
2. Machine Screw
(SS Truss Head 8-32 x 1)
3. Washer
4. Sleeve (SS) *
5. Spring (SS)
6. Washer
7. Bushing
8. Cam
9. Bushing
10. Woodruff Key (1/8 x 1/2)
11. Handle Body
12. D-ring
13. D-ring Cap
14. Machine Screw (2)
(SS Oval Head 8-32 x 3/8)
15. Lower Dowel
16. Upper Dowel
17. Set Screw (3) (SS 10-24 x 1/4)
18. Handle Locking Pin
19. Upper Ankle
20. Lower Ankle
21. Dowel Pin (SS 5/32 x 1)
22. Threads (M6 x 1) **
23. Socket Head Cap Screw
(SS M10) ***

Disassembly

- a. Unlock the ankle.
- b. Remove D-ring (12) and D-ring cap (13). Cut nylon tie-wraps and remove neoprene cover.
- c. At a point near the LOWER DOWEL (15), insert a flat-blade screw driver under the END CAP (1) lip. Pry up and remove END CAP.
- d. Using a Phillips screw driver, remove MACHINE SCREW (2).
- e. Remove WASHERS (3 and 6), SPRING (5) and SLEEVE (4). If any of these items remain lodged in the
 - a. center of the CAM (8), they can be pushed out after the HANDLE ASSEMBLY (10 thru 14) is removed in step 1.f.
- f. Pull the HANDLE ASSEMBLY from the UPPER and LOWER ANKLE (19 and 20).
- g. Insert shaft of Bushing Puller into CAM (8). Attach Bushing Puller to the BUSHING (7 or 9). Hand tighten the screws. **Do not over tighten** Push or tap end of shaft until BUSHING releases.
- h. Repeat step (1.g) to remove the other bushing.

Tools required:

- Bushing Puller (ACK)
- Teflon grease
- #2 Phillips screw driver
- Clean cloth
- Flat screw driver

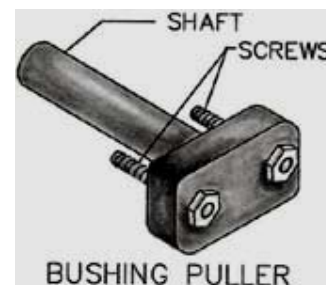

- i. Removing the cam from the ankle assembly requires accurate alignment of the bushing holes in the upper ankle and the large diameter (lobe) of the cam. **Grasp the ankle assembly in both hands** and while exerting thumb pressure on the cam end, slowly pull and rock at the ankle pieces until alignment is close enough to push out the cam. In some extreme cases it may be necessary to tap the cam out after proper alignment.
- j. Separate the upper and lower ankle pieces. No further disassembly is required for cleaning.

Cleaning

Wipe all parts thoroughly with a clean cloth. Soap and water or a mild solvent are OK.

*If parts are scored from sand, use a **fine** grit sandpaper or emery cloth to smooth scratches.

Reassembly

- a. Apply a thin coat of Teflon grease in the following places:
 - 1. Outside surface of CAM (8).
 - 2. The top groove, the large diameter bore and the vertical sides of the LOWER ANKLE (20).
 - 3. The inside bore of the two BUSHINGS (7 and 9).
 - 4. The small diameter shaft of the HANDLE BODY (11) and the WOODRUFF KEY (10).
- b. Slide the upper and lower ankle pieces together and align the cam and bushing holes.
Make sure that the upper and lower ankle halves are *matched (front and rear) correctly*.
- c. Insert the cam in the upper and lower ankle *bushing and cam holes* with keyway for woodruff key (10) on the same side of the ankle as the HANDLE LOCKING PIN (18). Press in place.
**If keyway for woodruff key (10) is at both ends of the cam, note the center hole diameter difference at each end of the cam. Insert the cam so that the cam's smaller hole end is on the same side of the ankle as the HANDLE LOCKING PIN (18).*
- d. Note the two small *puller plate attachment holes* in each bushing. With these holes ***facing out***, press both bushings into the ankle bushing holes. It may be necessary to *tap the bushings in place*.
- e. Align the WOODRUFF KEY (10) and install the HANDLE BODY (11) into the cam hole. Position over HANDLE LOCKING PIN (18).
- f. Refer to parts breakdown drawing and place items 3 thru 6 over the MACHINE SCREW (2). Apply a drop of Loctite® to the threaded end of the screw and install this parts group into the hole at the other end of the cam. *Do not over tighten screw*. It may be necessary to loosen screw 1/8 to 1/4 turn for handle to operate smoothly.
- g. Snap END CAP (1) into place.
- h. Reinstall neoprene cover, D-ring and D-ring cap.
- i. Install and securely tighten two new tie-wraps. Reassembly is complete.

If foot bolt insert does not have a flange with 4 shallow holes, tighten foot bolt to 15 foot pounds or 180 inch pounds or 2.1 kilograms per meter. Do not over tighten. Do not use Loctite® or any other bolt adhesive. Do not use lock washers. Do not stack washers. If foot bolt insert has a flange with 4 shallow holes, (*Activankle 91-100 and later*), tighten foot bolt according to foot manufacturers specifications or industry standards. Use of Loctite® or lock washers is OK.

